

MAXOUT™

Proven Dry Chemical Fire Protection



800 VEHICLE FIRES OCCUR EVERY DAY

A quick blast of MaxOut™ proven dry chemical fire protection can mean the difference between a minor annoyance and a major catastrophe.

H3R Performance offers four MaxOut™ fire extinguishers that have a proven track record in extinguishing the types of fires likely to occur in an automotive environment.

- Listed and rated by Underwriters Laboratories
- US Coast Guard Approved with bracket listed on UL label (MX250C, MX250R)
- Meets DOT requirements for RVs and Heavy Duty Trucks (MX250C, MX250R)
- High quality steel cylinders and all metal valve construction
- Rechargeable
- Steel mounting bracket
- Compact, lightweight, easy to use
- 6 year limited warranty
- Made in U.S.A.

All MaxOut™ models effectively smother and break the chain reaction of fires involving flammable liquids and pressurized gasses, and will not conduct electricity back to the operator. MaxOut™ models MX250C and MX250R are also highly effective at stopping fires of common combustibles like wood and paper. They are also great for marine or residential use.



	<table border="1"> <tr><td>Model</td><td>MX100R</td></tr> <tr><td>Agent</td><td>1.0 lb.</td></tr> <tr><td>Gross</td><td>2.2 lb.</td></tr> <tr><td>Height</td><td>10.0 in.</td></tr> <tr><td>Width</td><td>3.6 in.</td></tr> <tr><td>Diameter</td><td>2.6 in.</td></tr> <tr><td>UL rating</td><td>2B:C</td></tr> </table>	Model	MX100R	Agent	1.0 lb.	Gross	2.2 lb.	Height	10.0 in.	Width	3.6 in.	Diameter	2.6 in.	UL rating	2B:C
Model	MX100R														
Agent	1.0 lb.														
Gross	2.2 lb.														
Height	10.0 in.														
Width	3.6 in.														
Diameter	2.6 in.														
UL rating	2B:C														

The compact MX100R is perfect for storing under your dash or front seat. Fire engine red finish will not fade like anodized units on the market will.

	<table border="1"> <tr><td>Model</td><td>MX100C</td></tr> <tr><td>Agent</td><td>1.0 lb.</td></tr> <tr><td>Gross</td><td>2.2 lb.</td></tr> <tr><td>Height</td><td>10.0 in.</td></tr> <tr><td>Width</td><td>3.6 in.</td></tr> <tr><td>Diameter</td><td>2.6 in.</td></tr> <tr><td>UL rating</td><td>2B:C</td></tr> </table>	Model	MX100C	Agent	1.0 lb.	Gross	2.2 lb.	Height	10.0 in.	Width	3.6 in.	Diameter	2.6 in.	UL rating	2B:C
Model	MX100C														
Agent	1.0 lb.														
Gross	2.2 lb.														
Height	10.0 in.														
Width	3.6 in.														
Diameter	2.6 in.														
UL rating	2B:C														

This is the MX100R with a cool chrome finish. Who says safety has to be boring!

	<table border="1"> <tr><td>Model</td><td>MX250R</td></tr> <tr><td>Agent</td><td>2.5 lb.</td></tr> <tr><td>Gross</td><td>5.0 lb.</td></tr> <tr><td>Height</td><td>14.8 in.</td></tr> <tr><td>Width</td><td>4.5 in.</td></tr> <tr><td>Diameter</td><td>3.0 in.</td></tr> <tr><td>UL rating</td><td>1A:10B:C</td></tr> </table>	Model	MX250R	Agent	2.5 lb.	Gross	5.0 lb.	Height	14.8 in.	Width	4.5 in.	Diameter	3.0 in.	UL rating	1A:10B:C
Model	MX250R														
Agent	2.5 lb.														
Gross	5.0 lb.														
Height	14.8 in.														
Width	4.5 in.														
Diameter	3.0 in.														
UL rating	1A:10B:C														

Twice the size and power of the smaller extinguishers, plus an "A" rating for extra peace of mind. USCG Approved.

	<table border="1"> <tr><td>Model</td><td>MX250C</td></tr> <tr><td>Agent</td><td>2.5 lb.</td></tr> <tr><td>Gross</td><td>5.0 lb.</td></tr> <tr><td>Height</td><td>14.8 in.</td></tr> <tr><td>Width</td><td>4.5 in.</td></tr> <tr><td>Diameter</td><td>3.0 in.</td></tr> <tr><td>UL rating</td><td>1A:10B:C</td></tr> </table>	Model	MX250C	Agent	2.5 lb.	Gross	5.0 lb.	Height	14.8 in.	Width	4.5 in.	Diameter	3.0 in.	UL rating	1A:10B:C
Model	MX250C														
Agent	2.5 lb.														
Gross	5.0 lb.														
Height	14.8 in.														
Width	4.5 in.														
Diameter	3.0 in.														
UL rating	1A:10B:C														

Gleaming chrome finish adds an extra touch of class to any vehicle. Same specs as the MX250R. USCG Approved.

POINT OF SALE COMMUNICATION

Did you know that:

- 800 vehicle fires occur every day?¹
- One in three new car buyers would like to purchase a fire extinguisher for their vehicle?²
- Many states require that a Fire Extinguisher be UL Listed in order to be legally offered for sale?

These important facts emphasize both the need for automotive fire extinguishers in general, and the benefits of premium, UL listed MaxOut™ fire extinguishers from H3R Performance. Rely on the attractive self-sell packaging and versatile counter mat that can also function as a poster to help educate consumers about MaxOut™!



Most automobile fires begin in the engine. Short circuits, leaking fluids and faulty fuel delivery systems are common causes. Fires can also start in exhaust system manifolds, catalytic converters and even brakes.

Source: ¹ National Fire Protection Association. ² Industrial Market Research, Inc.

MOUNTING OPTIONS

The four MaxOut™ fire extinguishers come standard with aviation style mounting brackets. Stylish and versatile billet mounting accessories are also available. Band clamps fit 2.6" or 3.0" diameter fire extinguishers, and can be combined with the flat surface mount or either of the two roll bar mounts. Available in polished and brushed finishes.

Billet brackets

Billet Mounting Accessory (sold separately)	Polished	Brushed
Band clamp for 1.0 lb. fire extinguishers	BB100P	BB100B
Band clamp for 2.5 lb. fire extinguishers	BB250P	BB250B
Flat surface mount	BMF01P	BMF01B
1 5/8 in. roll bar mount	BMR01P	BMR01B
1 3/4 in. roll bar mount	BMR02P	BMR02B

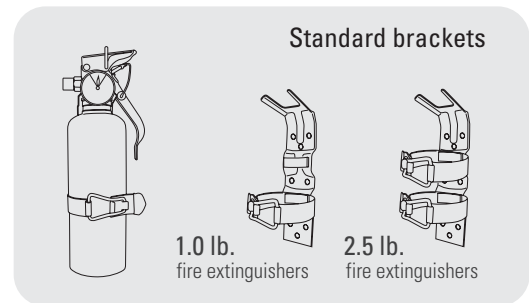

Polished



Brushed

Distributed by:

(800) 249-4289

www.h3rperformance.com